



SmartWasher[®]

BIOREMEDIATING parts washing system

Operating Manual

SmartWasher SW-33 Mobile Parts Washer



- ✓ Bioremediation Technology
- ✓ Powerful Cleaning Performance
- ✓ No Hazardous Waste Generation
- ✓ Non-Flammable

HELLO

Congratulations!

You have purchased the state-of-the-art SmartWasher® Bioremediating Parts Washing System. The SmartWasher® systems combine a powerful cleaning solution with the bioremediating power of specially-bred Ozzy® microbes. Once a SmartWasher® has been properly installed and activated, it is literally ALIVE!

Your SmartWasher®

- **IS** a safer alternative than using traditional solvents
- **USES** the latest in bioremediation technology to eliminate hazardous liquid waste
- **HELPS** deregulate and detoxify your workplace and reduce government paperwork
- **SAVES** you money

The SmartWasher® is designed to safely and effectively remove oil and grease from automotive and industrial parts. It replaces hazardous solvent parts washers with aqueous-based degreasing solutions called OzzyJuice® and microbe impregnated particulate traps called the OzzyMat®.

The microbes impregnated into the OzzyMat® come to life in the OzzyJuice® and break down, or “eat”, the grease, oil and other contaminants in the solution leaving by – products of harmless carbon dioxide and water – leaving nothing hazardous to haul away.

OzzyJuice® is an award winning, pH neutral, non-caustic, non-flammable and bioremediating degreasing solution. Working in concert with our microbes (Ozzy®) these superior products help eliminate or greatly reduce your need to dispose of hazardous waste, giving you all the performance you are accustomed to in a typical solvent parts washer without all the hazards and hassles. You have made a great decision.

Contents

Safety Instructions	3
Installation and Setup	4
Proper Use, Care and Maintenance	7
Frequently Asked Questions.	8
Troubleshooting.	10
SW-33 Sink Diagram.	12
SW-33 Base Diagram	13
SW-33 Replacement Parts	14
Warranty Registration	15

View the “How To” videos
on the CRC SmartWasher® machine set
up and maintenance at
www.crc.co.nz/smart-washer

Safety Instructions

BE SAFE

Please read this instruction manual carefully and completely to ensure that your new SmartWasher® will operate at its maximum effectiveness.

When using your SmartWasher®, basic safety precautions should always be followed, including:

- 1.** Care must be taken as burns can occur from touching hot parts.
- 2.** Do not operate SmartWasher® with a damaged cord or if the equipment has been dropped or damaged until it has been examined by a qualified service person.
- 3.** Do not let a cord hang over the edge of the table, bench, or counter or come in contact with hot manifolds or moving fan blades.
- 4.** If an extension cord is necessary, a cord with a current rating equal to or more than that of the equipment should be used. Cords rated for current lower than the equipment may over heat. Care should be taken to arrange the cord so that it will not be tripped over or pulled. (Must be rated a minimum of 5A/220V)
- 5.** Unplug equipment from electrical outlet when not in use for an extended period of time. Never use the cord to pull the plug from the outlet. Grasp plug and pull to disconnect.
- 6.** To reduce the risk of fire, do not operate equipment in the vicinity of open containers of flammable liquids (gasoline).
- 7.** Adequate ventilation should be provided when working on operating internal combustion engines.
- 8.** Keep hair, loose clothing, fingers, and all parts of body away from moving parts.
- 9.** To reduce the risk of electric shock, do not use on wet surfaces or expose to rain.
- 10.** Use SmartWasher® only as described in this manual. Use only attachments and parts recommended by CRC Industries.
- 11.** ALWAYS WEAR SAFETY GLASSES. Everyday eyeglasses only have impact resistant lenses, they are not safety glasses.
- 12.** It is good practice to wear gloves whenever using industrial cleaning fluids.

Installation & Setup

SET ME UP

Your SmartWasher® is almost ready to use. (The OzzyMat®, support grid and false bottom of the sink are packed inside the sink.) Visually inspect for damage (minor scratches and scuffs are normal due to the molding process).

- Remove the false bottom and check to make sure the mat support grid is in the bottom of the sink.
- Remove and discard packing material.

Parts Washer Setup

1. Remove the OzzyMat® from its package, unfold it and lay it on the mat support grid located in the lowest level in the sink. Make sure to lay the OzzyMat® white side up.
2. Place the false bottom in position in the sink.
3. Form the flexible nozzle to its desired shape and be sure that the parts brush is inside the sink.
4. **DO NOT PLUG UNIT IN BEFORE ADDING OZZYJUICE®.**
5. At start-up, carefully add OzzyJuice® to the SmartWasher® by slowly pouring the solution directly into the sink. Refer to the chart below for amounts.
6. Plug the unit into a 220VAC GFCI electrical outlet.
7. The SmartWasher® will take approximately four hours to heat up to its selected optimal temperature of 40°C (+-1°) OR 46°C (+-1°). This temperature will be maintained as long as the SmartWasher® is plugged in and full of OzzyJuice®. (If the “add fluid light” is on, the heater automatically shuts off.)

Fill Amounts

Parts Washer Unit	Start-Up Fluid
SW-33	60 L (3 x 20L containers)



Installation & Setup Continued

Parts Washer Operation

1. The pump switch is attached to a ten minute timer. Turning the switch ON (upward position) will start fluid flowing for ten minutes. To restart the flow, turn the switch OFF then ON again and the flow will restart for another ten minutes.
2. Adjust the valve at the base of the nozzle to control the flow of the fluid through the nozzle. The valve at the base of the brush hose controls the flow of fluid through the brush. Both outlets can be operated independently or together.

OzzyMat®



Change the OzzyMat® every 30 days or once a month to maintain cleaning performance.

The OzzyMat® traps sludge and dirt as small as 50 microns. It works effectively even when it appears dirty. At some point, however, it will become saturated and unable to pass fluid freely and should be changed. The FL-4 Multi-layer OzzyMat® allows you the benefit of being able to peel layers between mat changes.

OzzyMat® FL-4 Upkeep

1. Make sure the pump is not running.
2. Remove the false bottom from the sink.
- 3a. At 1 to 3 weeks: Peel away the top layer of the OzzyMat® and wring out any excess fluid. Then, dispose of this layer according to your local regulations.
- 3b. At 4 weeks: Remove the last layer of soiled OzzyMat® and set to one side of the filter support grid.
4. Remove a new OzzyMat® from its poly bag, unfold the mat and lay it on top of the filter support grid – white side up.
5. Roll up used OzzyMat® and stand vertically against the side of the sink to drain excess fluid. This will allow good fluid to drain from the used mat before disposal.
6. Take the old, used OzzyMat® and place it into the poly bag the new mat came in.
7. Return the false bottom to its proper position.
8. Discard used OzzyMat® in accordance with your local regulations.

Installation & Setup Continued

OzzyJuice® Degreasing Solution

The SmartWasher® uses a specially formulated fluid which provides a combination of excellent cleaning characteristics, safety and nutrition for the Ozzy® microbes. OzzyJuice® is provided in ready-to-use containers.



Adding OzzyJuice®

Slowly pour a full container of OzzyJuice® directly into the SmartWasher® sink. The “add fluid light” should go out when you have completed this process.

To help monitor and maintain the proper fluid level, the SmartWasher® is equipped with an “add fluid light”.

When the “add fluid light” light comes on the heater in the unit will turn off until an ENTIRE 20L container of OzzyJuice® is added.

The “add fluid light” light will shut off and the heater will come back on once the 20L container of OzzyJuice® is added to the SmartWasher®.

DO NOT ADD
Water, solvent, mineral spirits, gasoline or kerosene to your SmartWasher®

Temperature Settings

- Your SmartWasher® should be plugged in 24 hours a day, 7 days a week to maintain optimal temperature.
- Depending on the OzzyJuice® solution shipped with your SmartWasher®, the thermostat is factory-set to maintain fluid temperature between 40°C to 46°C (+/-1°). This temperature provides the optimum condition for effective cleaning and activity of Ozzy® microbes.
- The heater will not operate when the fluid level becomes critically low. Lift the sink and check your fluid level. When the “add fluid light” illuminates add (1) 20L container of OzzyJuice®. If, after a reasonable warm-up period, the fluid temperature seems too hot or too cold, please refer to the “Troubleshooting” section of this manual.
- If the temperature falls below the recommended minimum, the system will still clean, but remediation of the hydrocarbons by the Ozzy® microbe colony will slow down. However, the microbes will not die. The Ozzy® colony will become more active when the fluid temperature reaches the appropriate level.

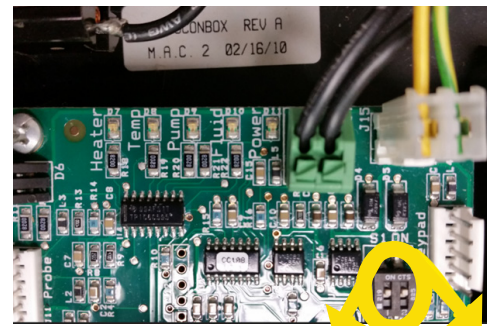

Pump Switch	Temperature Switch
Up: 10 minutes	Up: 40°C
Down: 30 minutes	Down: 46°C

Proper Use, Care & Maintenance

MAINTAIN ME WELL

Suggested Annual Maintenance

1. Pump out the fluid into containers until the machine is drained.
2. Unplug the SmartWasher®.
3. Remove the sink from the base. Inspect and remove any sludge that might have accumulated on the bottom of the unit.
4. Clean the base with water to remove any debris.
5. Visually check the condition of the hoses, connectors, etc. If everything appears to be in good working condition, reassemble sink, change OzzyMat®, and return the OzzyJuice® to the SmartWasher®.
6. Simply perform the annual maintenance described above and then add OzzyBooster® for an extra supply of microbes to bring your fluid back into conformity. If your fluid has developed an odor, you may also add Odor Neutralizer.
7. Maintenance may need to be performed more often depending on usage and/or application.

Change the OzzyMat®
To maintain the effectiveness and performance of the OzzyJuice® change the OzzyMat® once a month.

View the “How To” videos on the CRC SmartWasher® machine set up and maintenance at www.crc.co.nz/smart-washer

Frequently Asked Questions

ASK ME

What is BIOREMEDIATION?

Bioremediation is the use of biological agents such as microbes or plants to break down or neutralize “hazardous substances” or “contaminants” thereby removing hazardous chemicals from the environment. The process of bioremediation is listed as one of the Environmental Protection Agency’s (EPA) innovative technologies.

How is “Bioremediating” different from “Biodegradable”?

BIOREMEDIATION is the use of natural biological agents such as microbes to break down or neutralize “hazardous substances” or “contaminants”. FOR EXAMPLE: In the SmartWasher®, Ozzy®(s), natural biological agents or microbes, break down the carbon-based contaminants (grease and oil) and turn them into harmless carbon dioxide and water. BIODEGRADABLE means that a substance or mixture is subject to or could be broken down by biological agents into smaller compounds, in its virgin state only by natural means.

Who and what is Ozzy®?

Ozzy® is the name we selected for the blend of nonpathogenic (harmless to humans) microbes in the SmartWasher® system. Our microbes, Ozzy® eat potentially harmful hydrocarbon wastes in the SmartWasher® and transform these wastes into very small quantities of carbon dioxide and water. Similar types of microbes have been used for many years in various bioremediation applications, such as oil spills, including the Gulf of Mexico spill in 2010, and the Exxon Valdez disaster in 1989.

What happens to the grease, oil and other contaminants in the SmartWasher®?

Grease, oil and other contaminants are bioremediated in the SmartWasher® – transformed into harmless, non-hazardous by-products such as carbon dioxide and water. Particulate matter, such as sand, grit, dirt and paint chips are trapped in the OzzyMat® to be disposed of properly.

How well does OzzyJuice® clean?

OzzyJuice® is extraordinarily powerful and cleans extremely well. OzzyJuice® is a surfactant-based aqueous solution that breaks down the surface tension between the grease and the part rather than dissolving it; the grease actually lifts off the parts leaving behind clean surfaces. Note that while OzzyJuice® cleans differently than hazardous solvents or mineral spirits, it is just as effective.

Will OzzyJuice® clean carburetors, transmissions, aluminum, brakes and anything else in my shop?

YES. Not only is OzzyJuice® effective on these parts, it will not damage non-metal components that may be attached to the parts being cleaned such as rubber or plastic fittings. As with all parts cleaners, some items are going to become cleaner at different rates than others due to the degree and type of grime encountered.

How often do I change the fluid (OzzyJuice®)?

If you are changing your OzzyMat® a minimum of once a month, under normal use and with proper maintenance, you should never have to change or haul away used OzzyJuice®. This is one of the biggest advantages of the SmartWasher® system. Ozzy®(s) microbes clean contaminants from the fluid through the process of bioremediation. This leaves you with clean OzzyJuice® to work with day after day.

Why is the SmartWasher® heated?

Two reasons: First, it keeps Ozzy® eating at an optimal level to clean the solution as quickly as possible. Secondly, warm solution simply cleans better than cold solution. An added benefit to warm solution: it makes it more enjoyable to work with, especially in winter.

Why doesn't OzzyJuice® damage my hands like solvents?

OzzyJuice® is a pH-neutral, non-caustic, water-based formula that will not dry, crack or irritate the skin. Solvents can be caustic and pull fat cells from the skin, possibly causing extreme drying, redness, blisters, and other dermatological problems.

Can I use OzzyJuice® in other parts washers?

We do not recommend that OzzyJuice® be used in other parts washers. The OzzyJuice® and the SmartWasher® were made to work together with variables such as specific temperatures, compensation for foam, and so on. Also remember, the Ozzy®(s) microbes are in the OzzyMat® and if the OzzyJuice® is used in another machine it will not have the Ozzy®(s) microbes to clean the fluid.

Frequently Asked Questions

How much oil can I put into the SmartWasher® at a time?

As with all parts cleaners, excessive greases, oils and fluids should be disposed of prior to washing parts. The SmartWasher® can handle large, tough, dirty jobs, but was not designed to be – nor should be treated as – a waste oil dump.

Can I use other fluids in my SmartWasher®?

The SmartWasher® parts washing system has been developed to work effectively as a whole: SmartWasher®, OzzyJuice® and OzzyMat®. Other solutions may damage the machine or kill Ozzy®, thereby eliminating the advantages of the SmartWasher®. The use of other solutions in the SmartWasher® will void the warranty.

Can the SmartWasher® overheat if the OzzyJuice® gets low?

NO. The heater is automatically de-activated when the “add fluid light” indicator light is illuminated. While the pump will continue to operate, the heater will not be reactivated until (1) entire 20L container of OzzyJuice® is added to the system and the “add fluid light” indicator light is off.

Can I simply add water to the SmartWasher® to adjust the fluid level?

NO. Adding water will dilute the OzzyJuice®, severely impacting its performance.

How often do I add OzzyJuice® to the SmartWasher®?

The SmartWasher® comes equipped with an “add fluid light” which illuminates when you are low on fluid. When this light is on simply add (1) 20L container of OzzyJuice® to bring the fluid level up to normal. On average, with normal use, you will add (1) 20L container of OzzyJuice® approximately every six to eight weeks.

How quickly can Ozzy® break down oil and grease?

Once activated, the Ozzy® (s) are constantly eating. Assuming the system is operating optimally (OzzyJuice® temperature between 40°C - 46°C and the OzzyMat® routinely changed a minimum of once every 30 days) the rate at which the hydrocarbons can remediate can approach 80% every seven days. Analyses performed on samples of used OzzyJuice® from operating SmartWasher® systems consistently show oil and grease levels in the 1,400 parts per million range. BY COMPARISON, used, non-bioremediating, aqueous cleaners can average over 20,000 parts per million of oil and grease.

How often do I change the OzzyMat®?

At least once a month. This simple act accomplishes three things: First, it keeps trapped contaminants from reaching inappropriate levels. Secondly, Ozzy® microbes are introduced into the SmartWasher® system through the OzzyMat®. Every time you change the OzzyMat® you introduce fresh Ozzy®(s) to the existing microbe colony which keeps the system working at an optimum level. Finally, changing the OzzyMat® keeps sludge from building up in the base of the unit. If the OzzyMat® is not changed regularly and allowed to become clogged, large contaminants can flow into the reservoir via the overflow holes in the sink, potentially causing sludge to build up.

Does anything kill Ozzy®?

YES. Any biocides designed to kill microbes, such as bleach and Lysol®, will kill Ozzy®; chemicals that kill living things like some strong pesticides and rat poison may be harmful to Ozzy®.

How do I dispose of the OzzyMat®?

In many areas the OzzyMat® can be disposed of in a non-leaching, sealed manner, and disposed of as solid waste. But it must always be disposed of in accordance with the National, State or local regulations.

What do I do if the OzzyMat® clogs up quickly with grease?

The FL-4 OzzyMat® has 4 layers intended to be peeled away weekly, which helps eliminate unnecessary clogging. You need to make sure you are peeling away the individual layers on a weekly basis. Change the entire OzzyMat® on the 4th week OR every month. Make sure to remove any excess grease, dirt and debris from dirty parts prior to washing.

Is there a warranty for the SmartWasher®?

The SmartWasher® is warranted against defects for two years. For more detailed information, please refer to the warranty section of this manual or visit our website: www.crc.co.nz/smart-washer

Troubleshooting

SORT IT

Cold OzzyJuice®

Issue - COLD FLUID

THE HEATER AUTOMATICALLY SHUTS OFF.

Check to see if the "Add Fluid" indicators are lit. There should be approximately 28 cm of fluid in the machine when it is low.

If the "Add Fluid" light is lit, add a full 20L container of OzzyJuice® (the light should go out). Allow for a reasonable warm up period and then recheck.

Overheated OzzyJuice®

Issue - OVERHEATED FLUID

If the fluid becomes extremely hot and exceeds 49°C unplug the SmartWasher® and call CRC Technical Support on 1800 224 227.

OzzyJuice® Discolouration or Odour

Issue - FLUID Discolouration OR Odour

OzzyJuice® may become dark in colour due to dyes in oils or greases removed from dirty parts. This will not affect its cleaning power. If the fluid should develop a strong odour, it may be contaminated and you should call CRC Technical Support on 1800 224 227 for assistance in diagnosing the problem.

Spilled OzzyJuice®

Issue - FLUID SPILLAGE ONTO FLOOR

OzzyJuice® will cause the floor to become slippery. Use caution when walking in or near spilled fluid. To clean up an accidental spill of new, unused fluid simply soak up the solution with an absorbent material, (or wash spillage down the nearest sanitary sewer). If the spilled OzzyJuice® has been used, you must dispose of the spillage in accordance with local regulations. If left to dry, the fluid will leave a tacky spot on the floor that when wet, will again become slippery.

The Thermostat is factory-set to maintain the fluid at 40°C or 46°C (+-1°).

If excessive oil is dumped into the SmartWasher®, take the following steps to remedy the situation:

Issue - Excessive Oil Dumped in System

1. Unplug the SmartWasher® and lift the sink off the base.
2. Skim excessive oil off the top of the OzzyJuice® or place an absorbent pad on top of the fluid, soak up the oil and dispose of it in accordance with local regulations.
3. In extreme cases, it may be necessary to replace all of the OzzyJuice® in the SmartWasher®. Dispose of contaminated OzzyJuice® and OzzyMats® according to local regulations.
4. If you replace all of the OzzyJuice®, rinse the base of the SmartWasher® to remove all excess oil and dirt.
5. Once unit has been cleaned, replace the sink and add a new OzzyMat® and 60L (3 x 20L containers) of new OzzyJuice®.

Issue - Excessive Fluid Loss

With "normal usage" you should have to add a 20L container of OzzyJuice® approximately every 6 to 8 weeks."Normal usage" means the equivalent of several users in a 10 hour day in a standard maintenance, repair and operation facility or several users in a multiple bay garage facility.

Troubleshooting Continued

CHECKING for Problems:

Issue - Excessive Fluid Loss

1. Check the fluid temperature, If the temperature is above 49°C the probe is not working properly. Temperatures above 49°C will increase the rate of evaporation.. Please turn machine off at the wall and unplug. Then contact CRC NZ on 09 272 2700 for technical assistance.
2. Examine closely where the sink and base meet. Are there any gaps? Is the base bowed? Is the sink warped? The SmartWasher® operates as a closed system; any gaps will provide space for air to enter and condensation to escape.
3. Is the SmartWasher® “leaking”? Where is it “leaking” from? Make sure the nozzle and brush are flowing into the sink. If the fluid is leaking from the body of the base? The base will need to be replaced.
4. If none of the previous apply, this rules out any problem with the SmartWasher® itself. Make sure you and your co-workers are aware that certain practices can cause you to use excessive amounts of OzzyJuice®. Refer to “Checking Practices” section on this page.

Issue - Low or No Fluid from Brush/Nozzle

Check the following:

1. Make sure that the valves at the base of the nozzle and brush are open. If a stronger flow through either device is needed, turn the valve on the unused tool to the closed position.
2. Hoses from the pump to the nozzle and brush could be clogged, pinched or disconnected. Check the hoses from the pump to the nozzle making sure they are in working order.
3. Make sure SmartWasher® is not low on fluid.
4. Hose connections should be secure and not leaking.
5. The pump comes with a two year factory warranty. If the pump is faulty, call CRC Technical Support on 1800 224 227 to order your warranty replacement. Have the serial number of the SmartWasher® unit available when calling.

CHECKING Practices:

- **How often, how much and when are you adding fluid?**

A full 20L container of OzzyJuice® should be added immediately when the “Add Fluid Light” comes on. The system is designed to warn users at the point at which fluid should be added. Please keep in mind that the light will remain illuminated while fluid is low, and more fluid will be needed to reach the proper operating level.

- **When did you notice the change in usage?**

If fluid usage has been fine for a period of time and usage has just recently increased, check to see if anything has changed recently. (New employees, more employees, more parts being cleaned, longer hours of use, etc.)

- **How many hours a day do you have the pump running?**

The more the pump runs, the more evaporation occurs. Never leave the pump running when the SmartWasher® is not in use.

- **How many operators and how many hours a day are you using the SmartWasher®?**

This will help you determine if they have high, normal or low usage. If you have higher than normal usage, you will have higher fluid usage.

- **Does the OzzyMat® clog up and cause the fluid to pool up in the sink?**

If the fluid is backing up in the sink and not draining through the OzzyMat® properly, there will be increased evaporation and the low fluid light may come on prematurely because the fluid is in the sink, not in the base. Please refer to FAQ section and read question “What do I do if the OzzyMat® clogs up quickly with grease?”.

- **Are operators squeezing the excessive fluid out of the OzzyMat® into the sink after installing a new OzzyMat®?**

When changing out the old OzzyMat®, roll up used OzzyMat® and stand vertically against the side of the sink to drain excess fluid.

SW-33 Sink Diagram

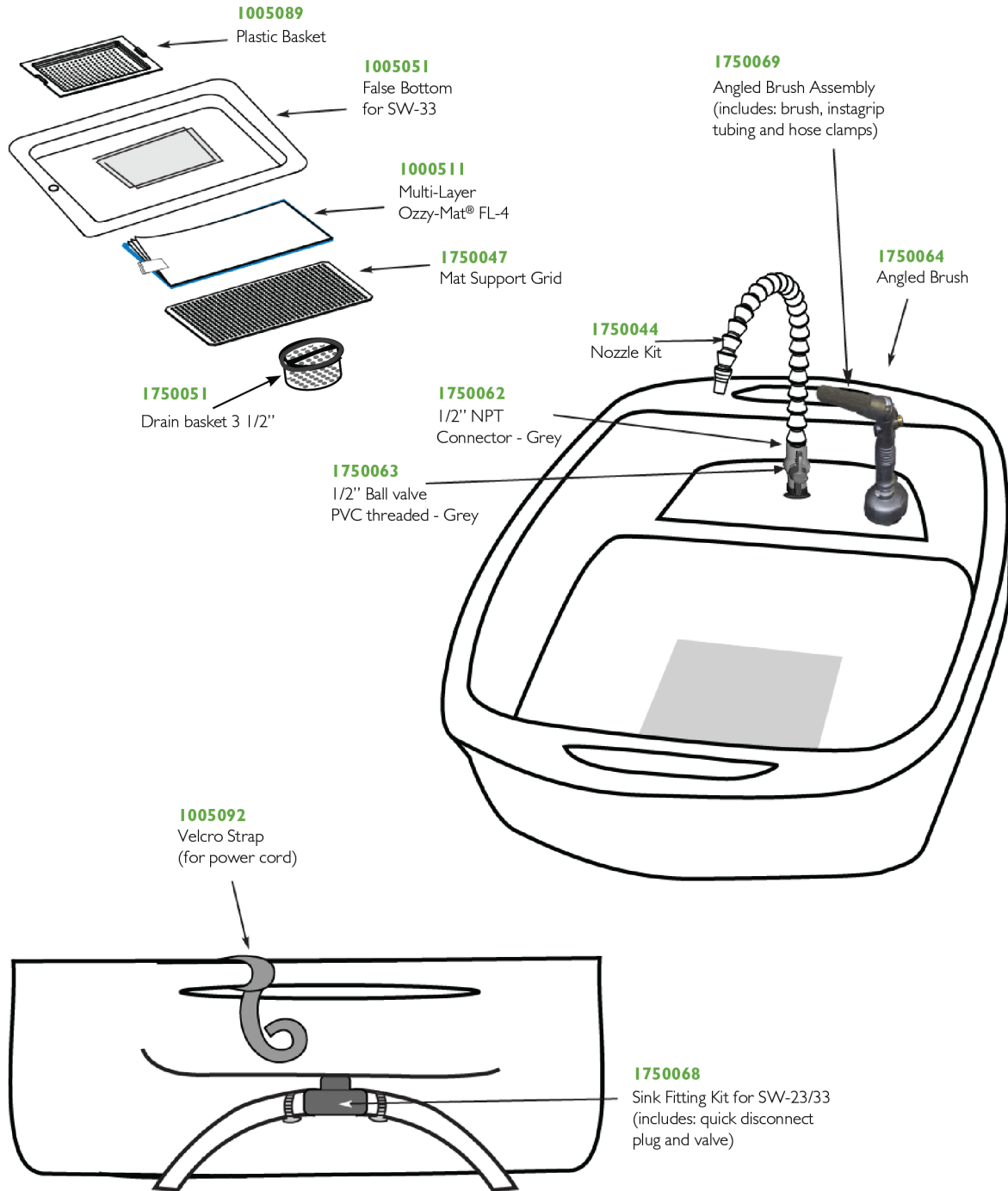

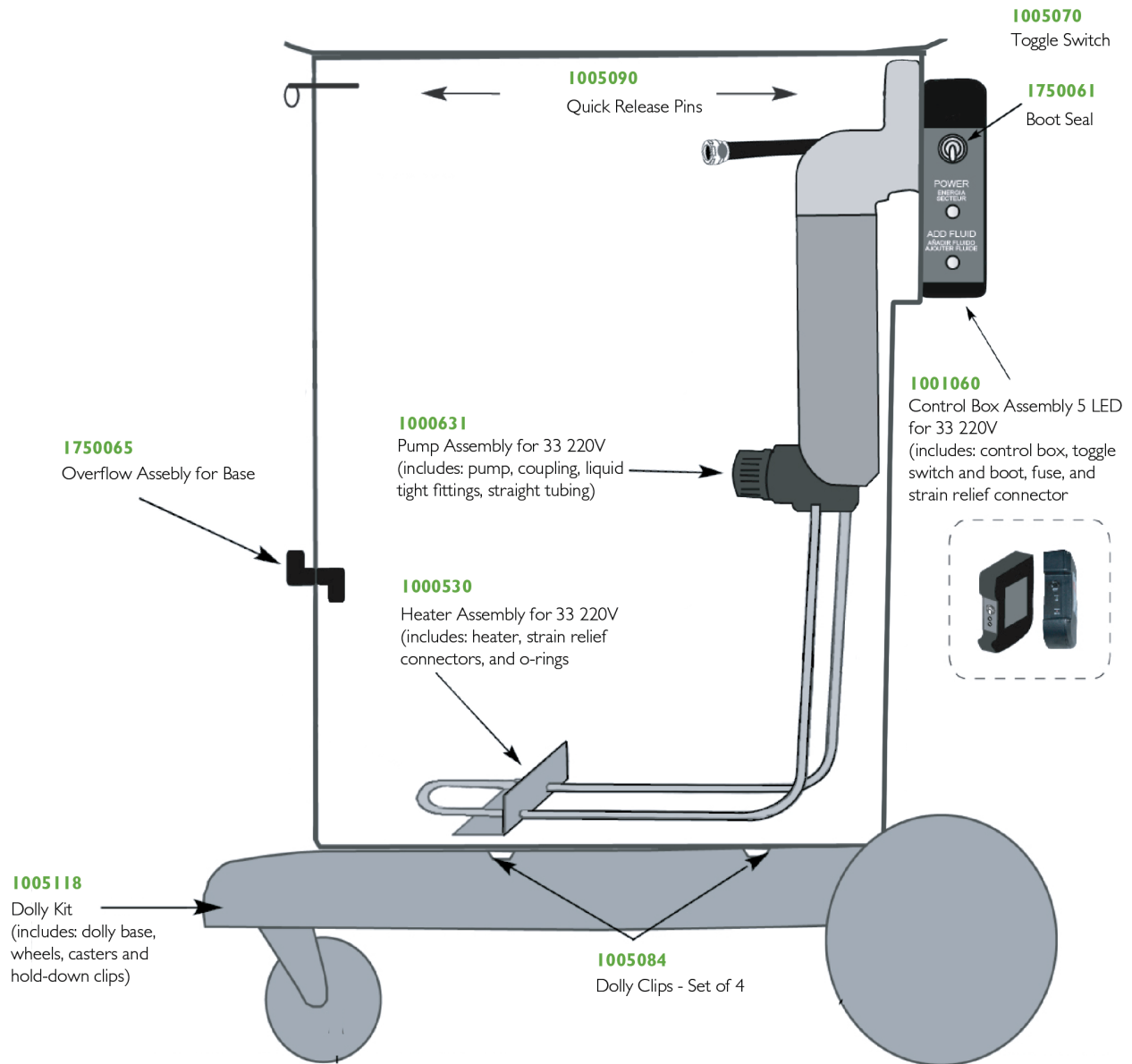

**FRONT AND SIDE VIEW
Control Module 33**

1000545

Control Module 33 220V
(includes: pass thru, support bracket, control box assembly, power cord, heater assembly, probe, pump assembly, and hose kit)

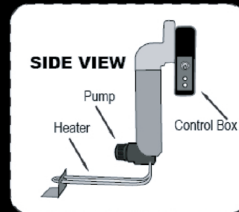
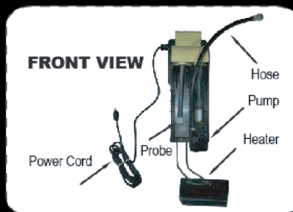

**Additional Items for
Model SW-33**

1000060
Heater Fuse

1750060
Pump Fuse

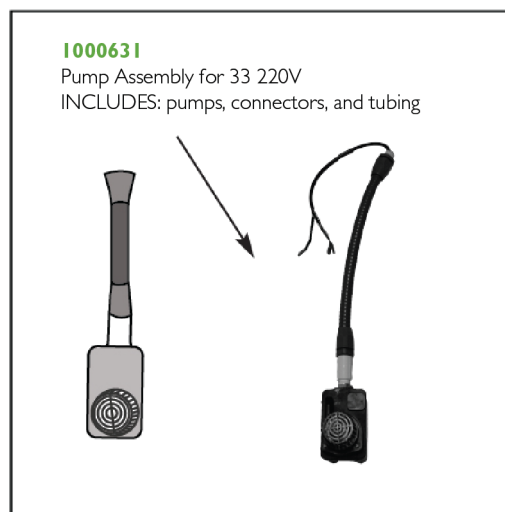
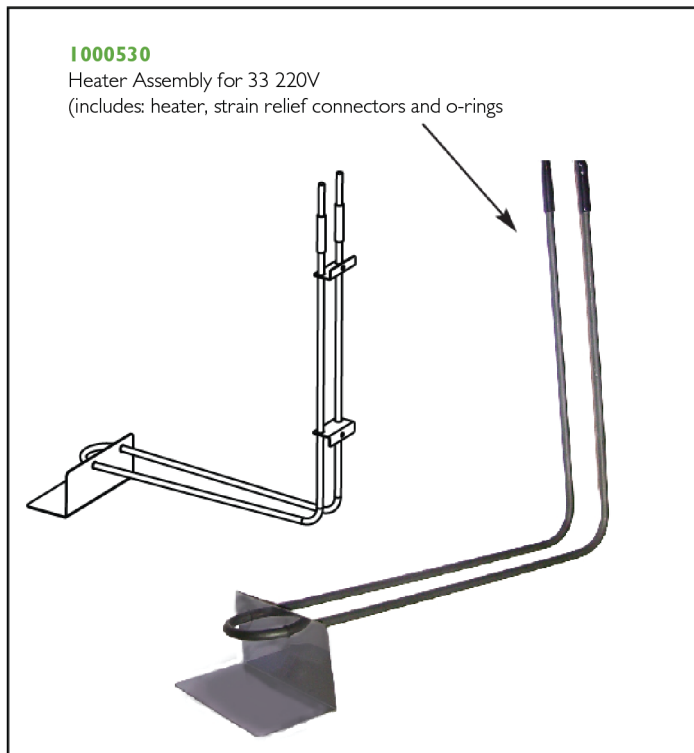
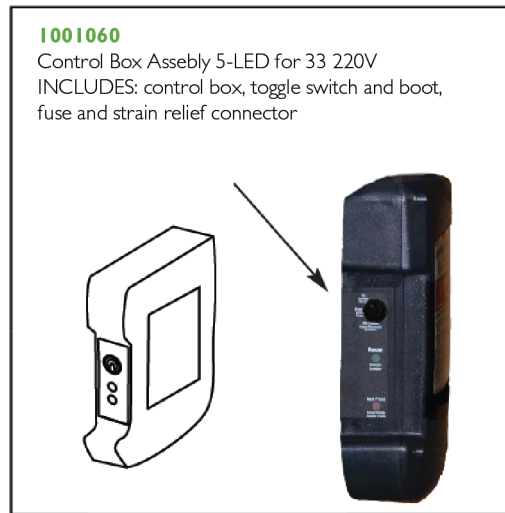
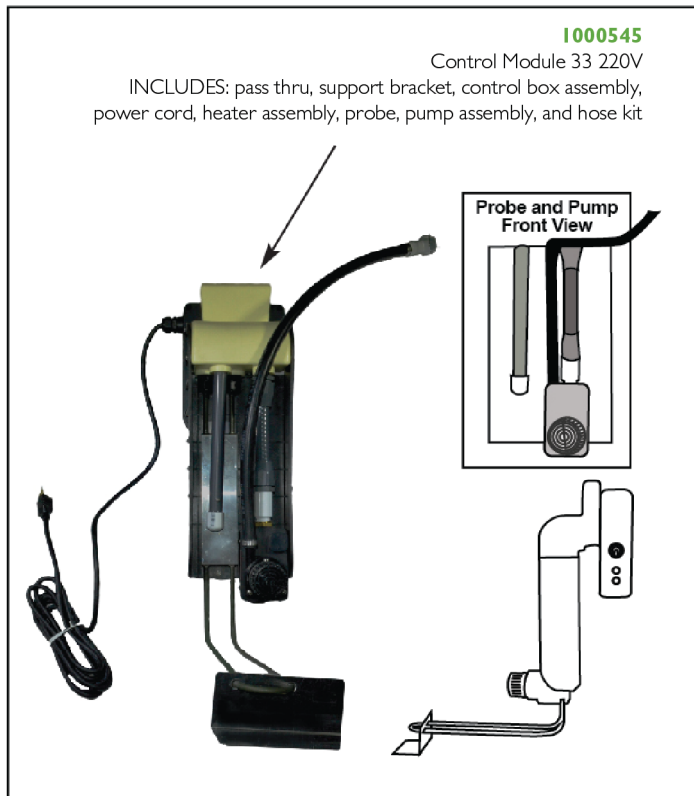

Warranty Registration

WARRANTY

This warranty relates to the CRC SmartWasher® accompanied by this warranty and purchased in New Zealand (**Product**).

CRC will repair or replace any part or parts found to be defective in material or workmanship within two (2) years from the date of purchase.

In the case of consumables (including cleaning brush), warranty does not apply to fair wear and tear. The 2 year Warranty covers products defective due to material or workmanship only.

This warranty applies only to the original purchaser of the Product (End User or you) and is non-transferrable.

Users are reminded to only use the Product in accordance with the Product Installation and Operating Instructions. Additional copies of the Operating Instructions are available from **CRC Customer Service Ph: 09 272 2700**

In the event of any modification to the Product, misuse, negligence or accident, or the use in the Product system of fluids, filters or additives other than those specifically authorised by CRC NZ, this warranty is void.

Any claim under this warranty must be made within the relevant Warranty Period. To lodge a claim under this warranty please contact us using the details below. You will need to:

- provide proof of the purchase date of the Product (or have registered the Product with CRC at the time of purchase);
- provide the Product serial number;
- in the case of a claim relating to parts, return the part to CRC;
- in the case of a claim relating to the Product body, provide photographic evidence and/or allow inspection by a CRC representative; and
- comply with all other reasonable requests of CRC.

All costs associated with lodging the warranty claim including the possible return of goods to CRC or our nominated distributor are the responsibility of the owner of the machine. This warranty is provided in addition to other rights and remedies you have at law.

If the End User is a consumer, the Product comes with guarantees, which cannot be excluded under New Zealand consumer laws and this warranty applies in addition to those rights and guarantees.

This Warranty is provided by:

CRC Industries NZ

10 Highbrook Drive, East Tamaki
Auckland 2013, New Zealand
www.crc.co.nz

Technical Assistance:

Email: swtechsupport.anz@crcind.com
PH: 09 272 2700

DISCLAIMER

The SmartWasher® is designed exclusively for removing oil and grease from automotive and industrial parts, and then remediating the residue. Any other use of the system, such as dumping waste oil, is not recommended and will cause damage to the system.

CRC Industries NZ cannot be responsible for any damage resulting from improper, inappropriate, or unauthorized use.



SmartWasher[®]
BIOREMEDIATING parts washing system

CRC Industries NZ

10 Highbrook Drive, East Tamaki
Auckland 2013, New Zealand
www.crc.co.nz/smart-washer
PH: 09 272 2700